

Baker Hughes 



Baker Hughes 



Baker Hughes Energy Valley Project

UNIFI – Honours Programme

November 27, 2024

Copyright 2024 Baker Hughes Company. All rights reserved. The information contained in this document is company confidential and proprietary property of Baker Hughes and its affiliates. It is to be used only for the benefit of Baker Hughes and may not be distributed, transmitted, reproduced, altered, or used for any purpose without the express written consent of Baker Hughes.

Agenda

- Baker Hughes Overview (Luca Palatiello)
- New Energy (CCUS, Hydrogen, Clean Power) (Vale & Michela)
- Honours Programme : Manufacturing Technology (NP MFG Team)
- Honours Programme : Supplier Quality (Chiara Brunetti)
- Continuous Improvement : LEAN (Massimo Guidi)
- Final Wrap-Up (Luca Palatiello)



We take energy

We are Baker Hughes, an energy technology company. Together, we're making energy safer, cleaner, and more efficient for people and the planet.

Energy for today and tomorrow

The energy sector is changing, faster than ever before. The energy trilemma—solving for energy security, sustainability, and affordability—is rebalancing our priorities and creating a new path forward for the industry. We believe we can meet those objectives together.

forward

Why Baker Hughes

Where there's demand, we deliver.



People & culture

Our ability to deliver energy tech leadership, integrated solutions, and customer focus is unmatched. By combining our unique strengths, we're making cleaner, more reliable, and more efficient energy a reality.

We are a people-first company, driven by a relentless pursuit to serve our communities, and working together to achieve our shared vision.



Advanced technology

Our highly engineered, connected technologies are what the world relies on to meet energy demand now, while redefining what's possible in the future.



Low carbon & sustainability

As the leaders in energy technology, we are setting the pace, delivering a sustainable energy transition and cleaner energy future, faster.



Solutions & scale

We're the only energy tech company with the portfolio, scale, and reach to develop reliable, cleaner energy solutions for today and tomorrow.

2023 highlights

PERFORMANCE

\$30.5B

in orders

26%

increase in adjusted EBITDA*

\$2.0B

in free cash flow*

TECHNOLOGY AND INNOVATION

\$658M

in research and development

>2,000

patents granted

\$750M

in new energy orders

ESG LEADERSHIP

AA

ESG rating by MSCI

28%

reduction in Scope 1 & 2 GHG emissions**

199

HSE perfect days

ABOUT BAKER HUGHES

~58,000

employees

\$25.5B

in revenue

120+

countries where we conduct business



Leading Energy Technology Company

1. Why we exist

The benefits we bring to customers and society and anchor us in the energy trilemma. Importantly, customers are seeking productivity and efficiency along with solutions to Net Zero.

2. How we deliver

One Baker Hughes through the common roles we play in clients' ecosystems.

3. Where we play

Our key technology (vectors/spaces) aligned to technology solutions areas.

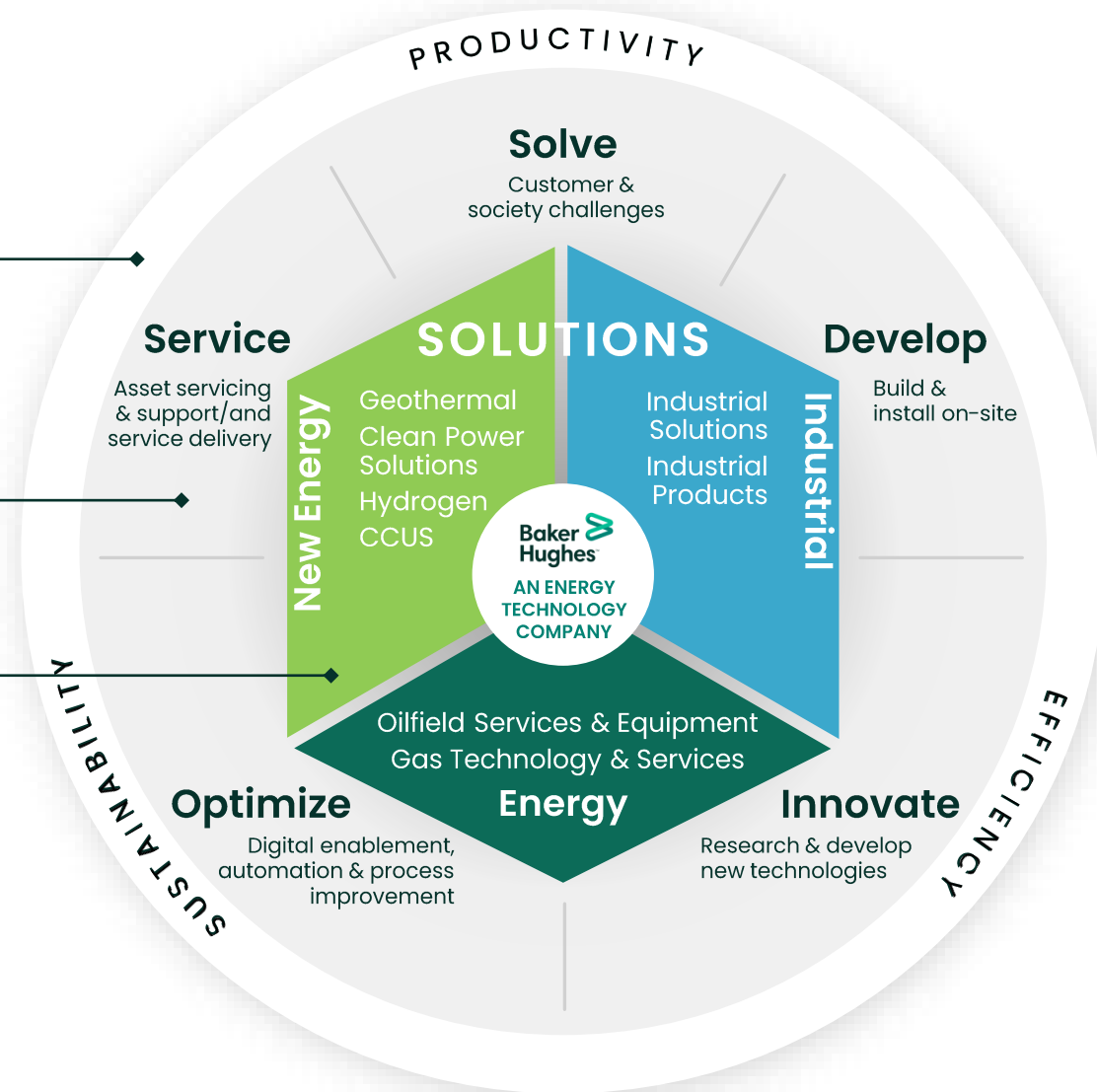

Investing for growth today and tomorrow

\$2.1B of strategic acquisitions and investments



Carbon capture, utilization, and storage



Modular Carbon Capture technology
Nov 2020



Exclusive license for mixed-salt capture
Mar 2021



Bio-methanation & synthetic natural gas technology investment
Jun 2021



Next-gen Direct Air Capture technology
Apr 2022



Polaris carbon storage project in Norway
Mar 2021



Industrial process equipment and technologies for CO2 Capture
Feb 2022



Project developer that utilizes CO₂ & H₂ to produce eFuels
March 2023



CCS hub for Norwegian Industrial Cluster
Jun 2021

Hydrogen



Methane pyrolysis technology to produce turquoise H₂
Nov 2021



Early-stage hydrogen technologies
Dec 2021



Low-pressure, low-temperature, high-value graphene production system
Nov 2022



Hydrogen compression and turbines for multiple projects
Jun 2021



Hydrogen infrastructure investment platform
Anchor Investor
Apr 2021



Electrochemical Hydrogen Compression collaboration
Dec 2023

Clean power solutions



Clean integrated power and hydrogen solutions
May 2021



Technology development & global deployment of zero-emission power plants
Feb 2022



Next-gen energy network delivering efficient, compact system
Sept 2022



Highly-efficient long duration energy storage technology
Sept 2022

Digital



Reliability and industrial asset management solutions
Feb 2021

Oilfield services & equipment



Well intervention services & downhole technology
Mar 2022



Advanced artificial lift and electrical submersible pumps technology
Jul 2022

Gas & industrial



Inspection solutions for critical infrastructure
Mar 2022



Power Generation

Electrification equipment, generators, and motors
Aug 2022

Geothermal



Closed loop geothermal technology
Mar 2022

Climate Technology Solutions to support decarbonization Enabled by growth in digital technology offerings

Carbon Capture Utilization & Storage



- Consultation & feasibility
- CO₂ capture & liquefaction
- Compression & transportation
- Subsurface storage
- Integrity and monitoring

Hydrogen



- Solutions for production, transportation & storage
- Hydrogen-fueled gas turbines – H₂ blends and 100% H₂
- Wide range of hydrogen compression solutions
- Integration capabilities for optimized design and operations

Clean Power Solutions



- Clean power generation and energy efficient solutions for decentralized and industrial applications
- Digitally augmented low- to no carbon-only portfolio

Emissions Management



- Aerial and land-based emissions monitoring
- Real-time analytics
- Equipment upgrades and operational process efficiency

Hydrogen fueled gas turbines

100+ Years of experience with H ₂	70+ Installed GTs burning H ₂ up to 100%	2009 First 100% H ₂ fueled gas turbine in commercial project
--	--	--

State-of-the art gas turbine
100% H₂ Ready GT Package

2023
NovaLT™16

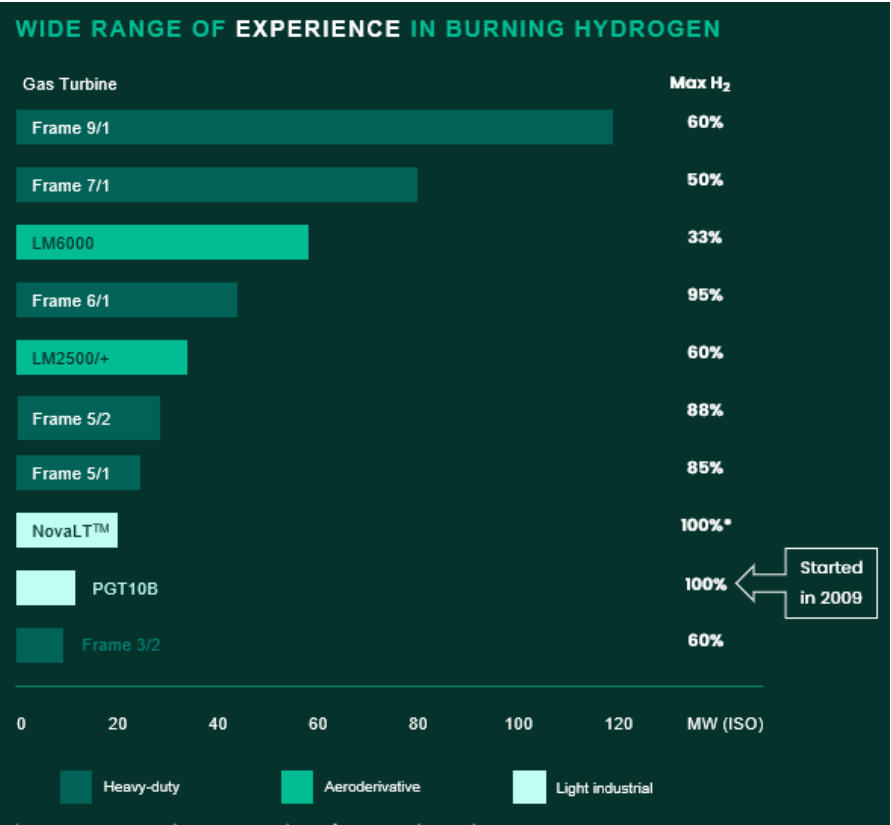

Hydrogen power plant in Fusina (Italy)

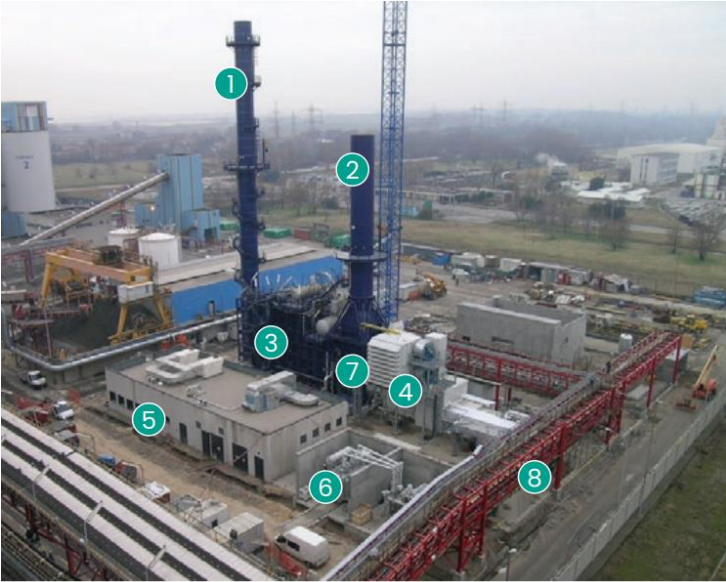

- 1. Dry flue gas stack
- 2. Bypass stack
- 3. Heat recovery steam generator (HRSG)
- 4. PGT10 gas turbine
- 5. Control room
- 6. Transformer
- 7. Diverter
- 8. Piping rack

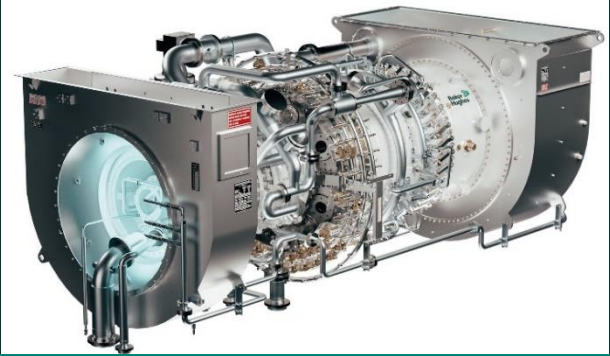

Blue H₂ project (Edmonton - Canada)

Providing **100% hydrogen fueled NovaLT™16** gas turbine technology to Air Products



Saving **70000+ Tons/Y** carbon emissions (each unit) burning 100H₂ (compared to burn natural gas)

GT Nova LTTM16

<https://www.youtube.com/watch?v=7xdBjz6f000>

Compressors RoadMap – Focus on Energy Transition

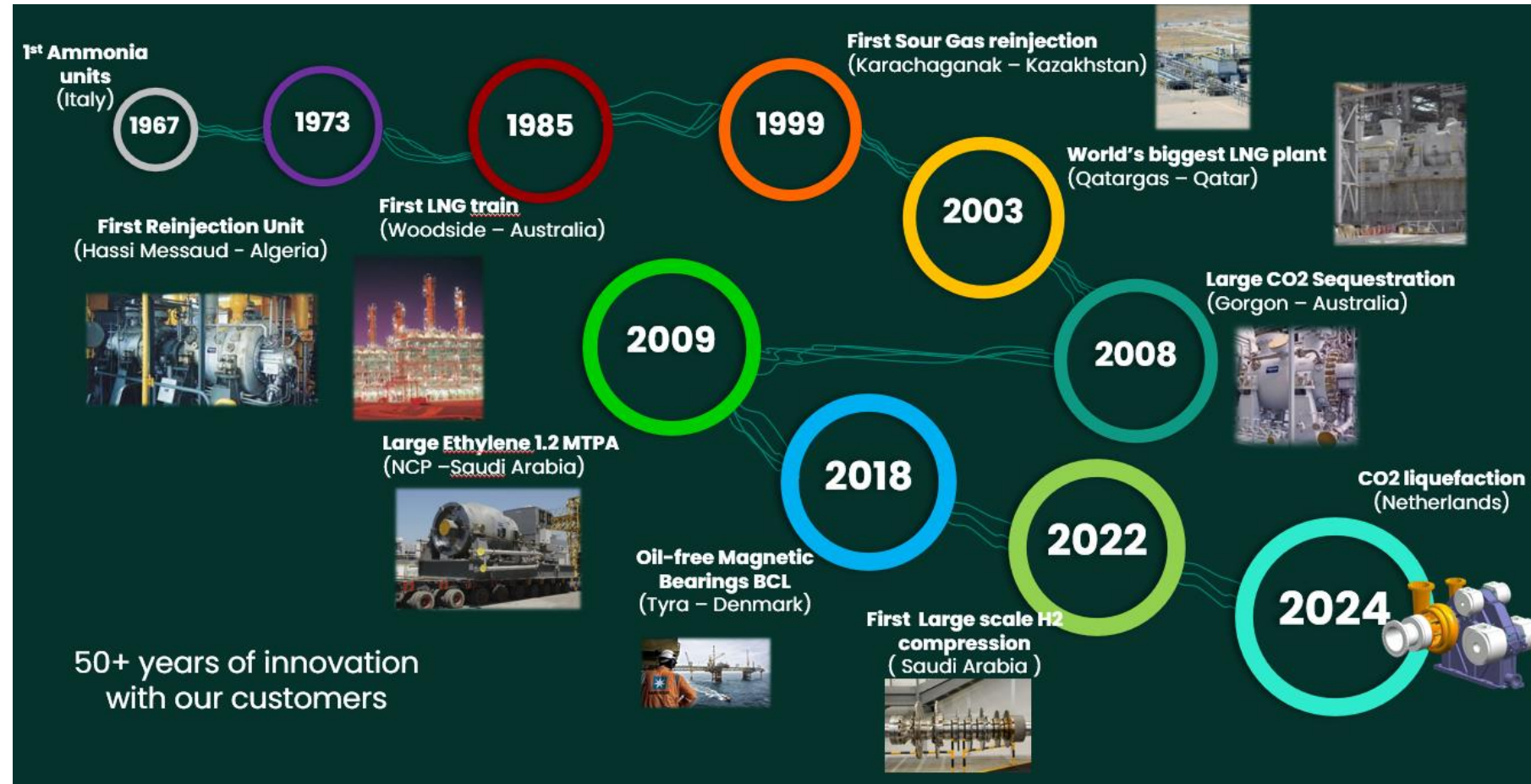

H2 Compressors for Neom – The Line

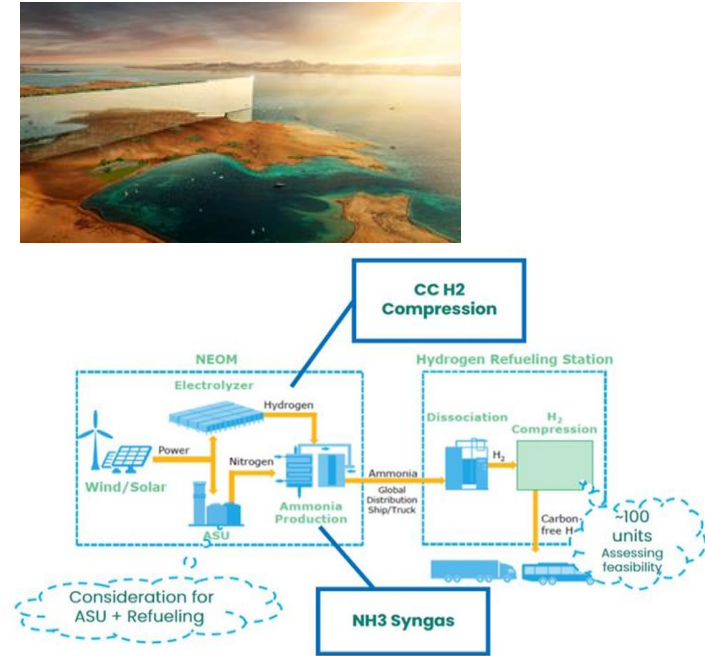

CC-Carbon Capture Development for industrial applications

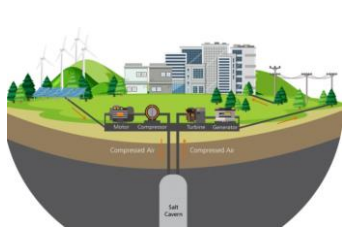

CAES – Compressed Air Energy Storage

ICL zero-emissions* integrated compressors



Challenge on Supercritical CO2 Compression – eg. Small Nuclear Reactor

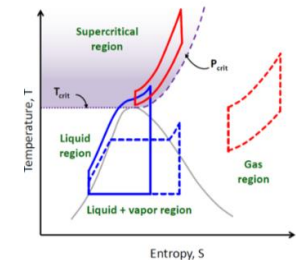

Our Corporate Responsibility framework

Committed to sustainability

Led by our purpose of making energy cleaner, safer, and more efficient for people and the planet



Baker Hughes ESG ratings and rankings



Awarded AA ESG rating by MSCI



Awarded C rating by CDP



Awarded B+ ESG rating & ranked No.3 in our industry



Industry Leader 2024



Awarded Silver Medal by ecovadis



CDMP Competency Programs in Baker Hughes

Sourcing & Procurement

Supplier Quality Engineers (SQE)

BUYER

COMMODITY/
SOURCING
LEADER

Supplier
Fulfillment
Manager (SFM)

Supplier
Performance
Manager



Manufacturing

Manufacturing
Engineering
(ME)

Materials
Planner (MP)

PQE \ QIC

Logistic/
Warehousing/
Shop Floor
Operator

HSE & Quality

Quality
Specialist

HSE
Specialist

4000+ Employees GSC & HSE/Q covered by CDMP

Make our Technical Training Experience available for Students

Honour Programme Manufacturing Technology

November 27, 2024

Copyright 2024 Baker Hughes Company. All rights reserved. The information contained in this document is company confidential and proprietary property of Baker Hughes and its affiliates. It is to be used only for the benefit of Baker Hughes and may not be distributed, transmitted, reproduced, altered, or used for any purpose without the express written consent of Baker Hughes.

Compressors

<https://youtu.be/zgqIZJ0xBvs>

Energy Valley

Honour Programme

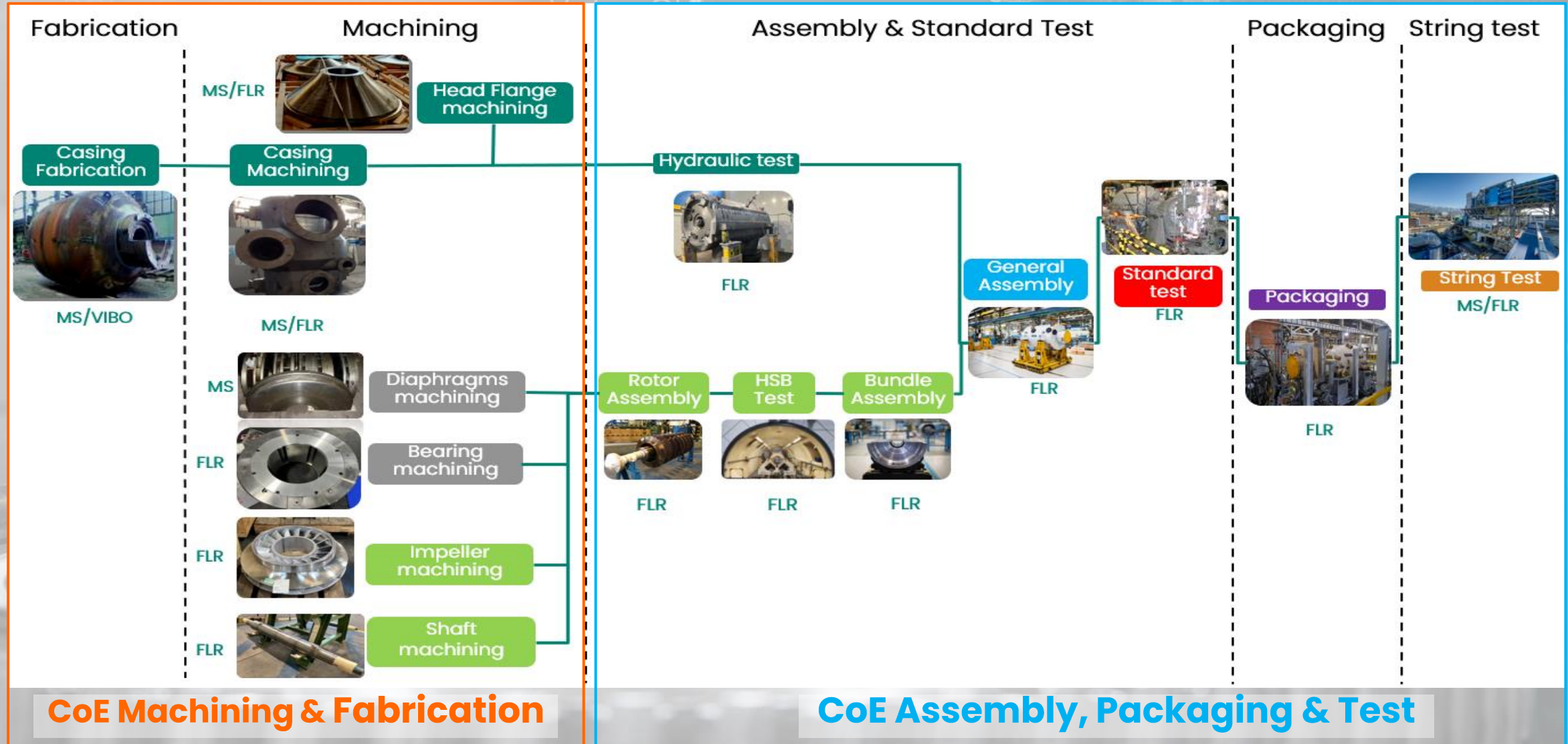

Energy Valley

3 Paths → 1 Technology Matrix

Honours Programme

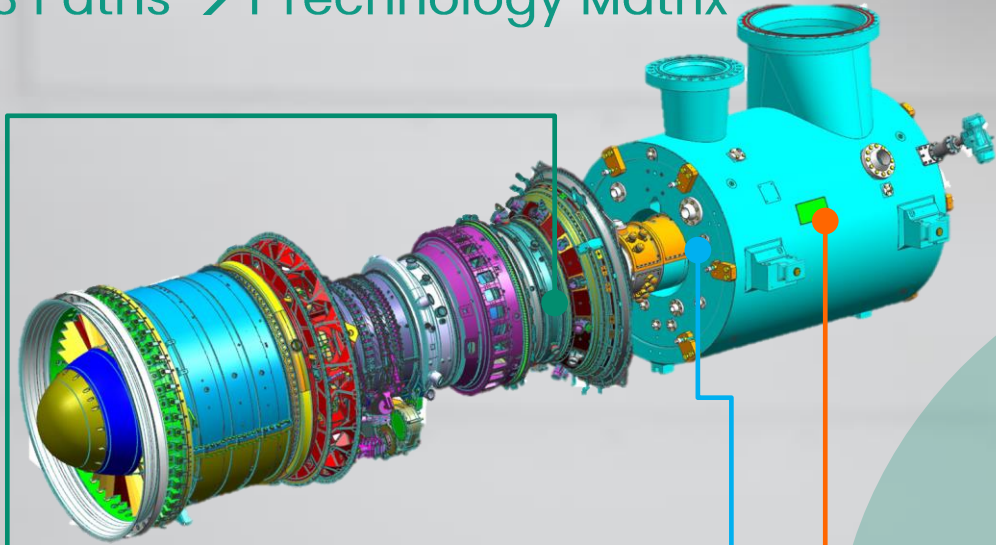

- Centrifugal Compressor Head Flange
- Centrifugal Compressor Impeller
- Gas Turbine Wheel

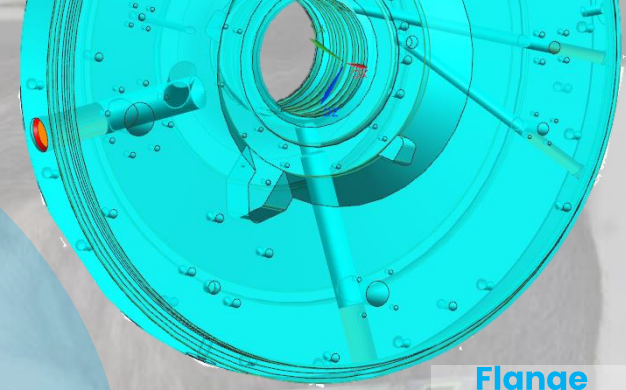

Energy Valley

Centrifugal Compressor Impeller Path

Honours Programme

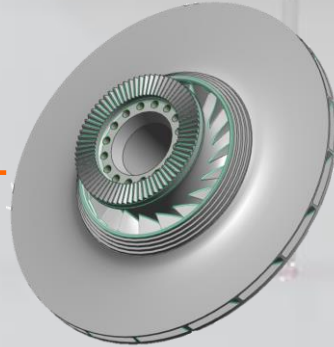
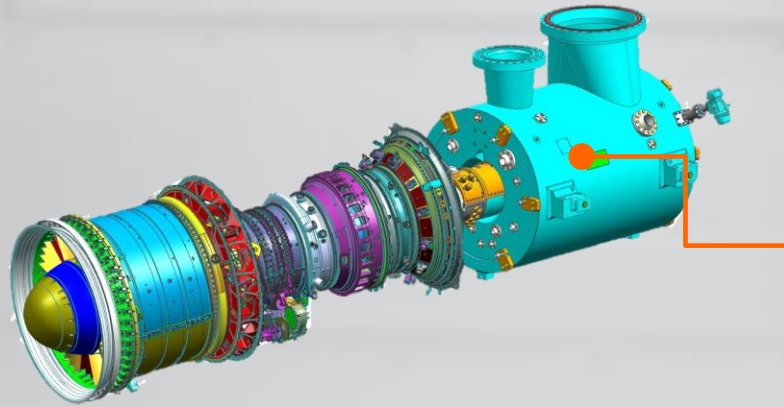

HPRC Impeller (H2)

5-Axys Miling

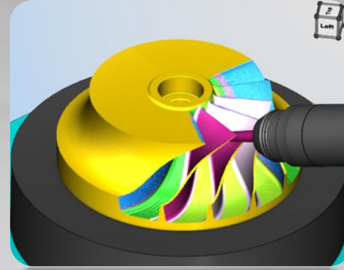

Electrical Discharge Machining (EDM)

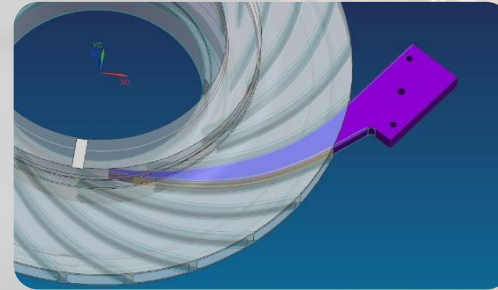

Routing... Manufacturing strategies to address different materials and technologies

Conventional Machining... Method/Tooling selection and CAD/CAM to enhance quality and productivity

Electrical Discharge Machining (EDM)... a key technology for complex vane's geometry and low accessibility

Heat Treatments... Special process control

Rotodynamic... Vertical and Horizontal Balancing and Overspeed Test

Quality... CMM for 100% CTQs check

Heat Treatments

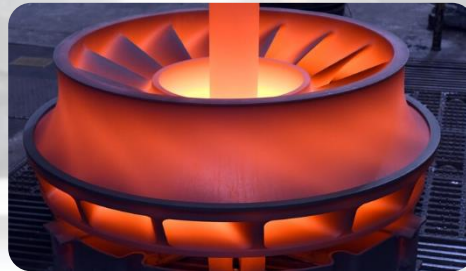

Balancing and Overspeed

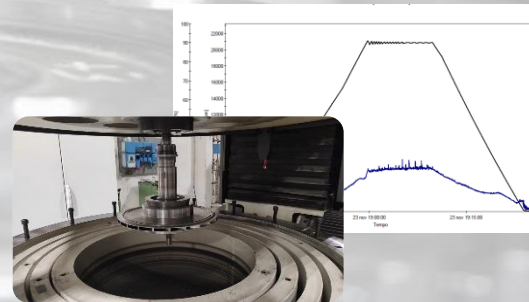

CMM

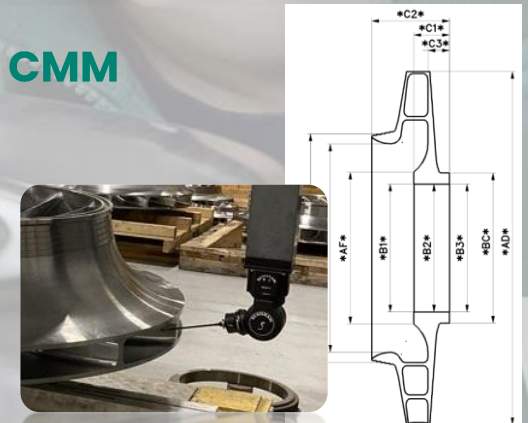

Energy Valley

Gas Turbine Wheel Path

Honours Programme

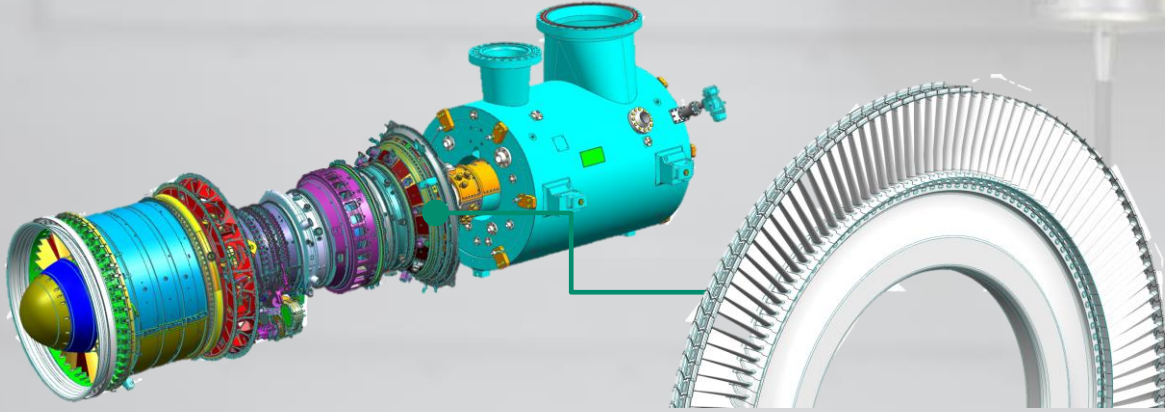

Turning/Milling operation

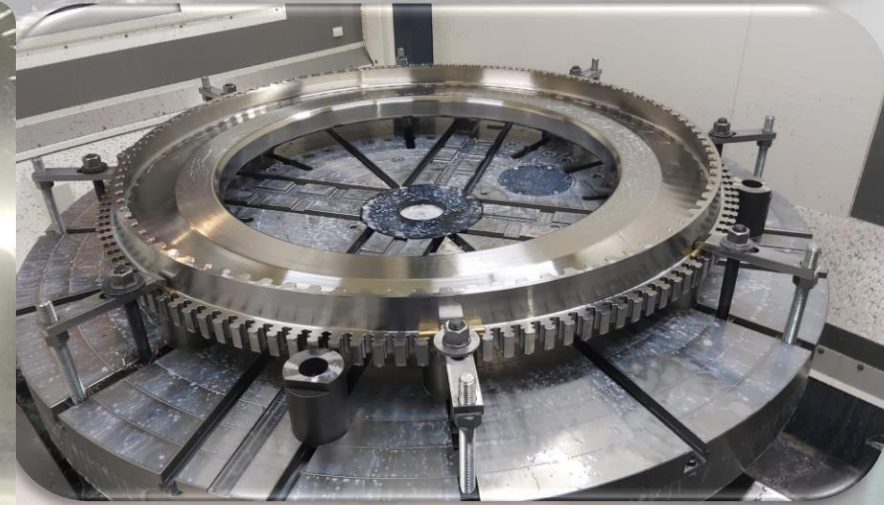

Conventional Machining... Method/Tooling selection and CAD/CAM to enhance quality and productivity

Wire EDM and broaching... Twin technology approach for dovetail execution

Overspeed... Special process to have longer component life

Rotodynamic... Vertical and Horizontal balancing

Material... High performance material → SS or HRSA (Nickel based alloy)

Quality... CMM for 100% CTQs check

Twin approach for wheel dovetail

Wire EDM

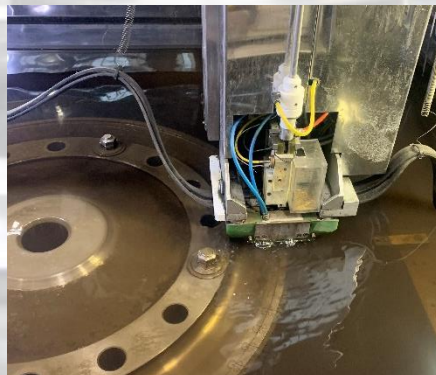

Broaching



Energy Valley

Centrifugal Compressor Head Flange Path

Honours Programme

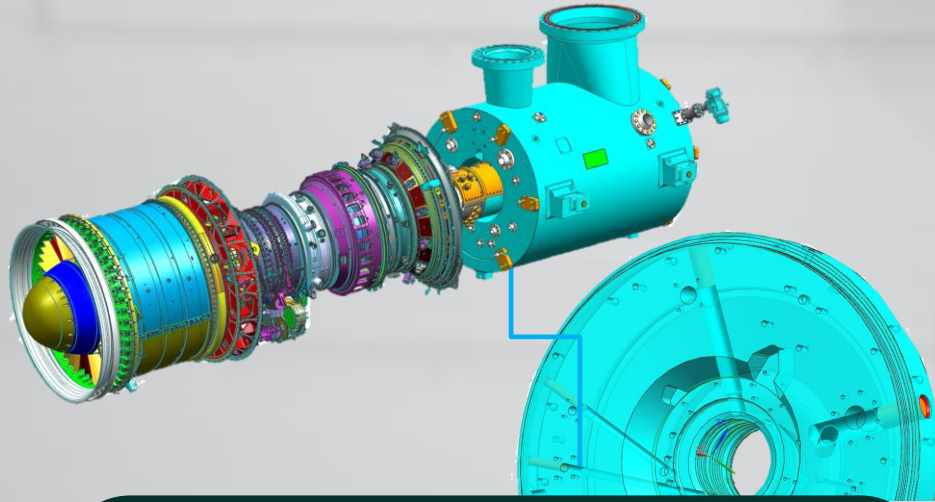

Deep Drilling

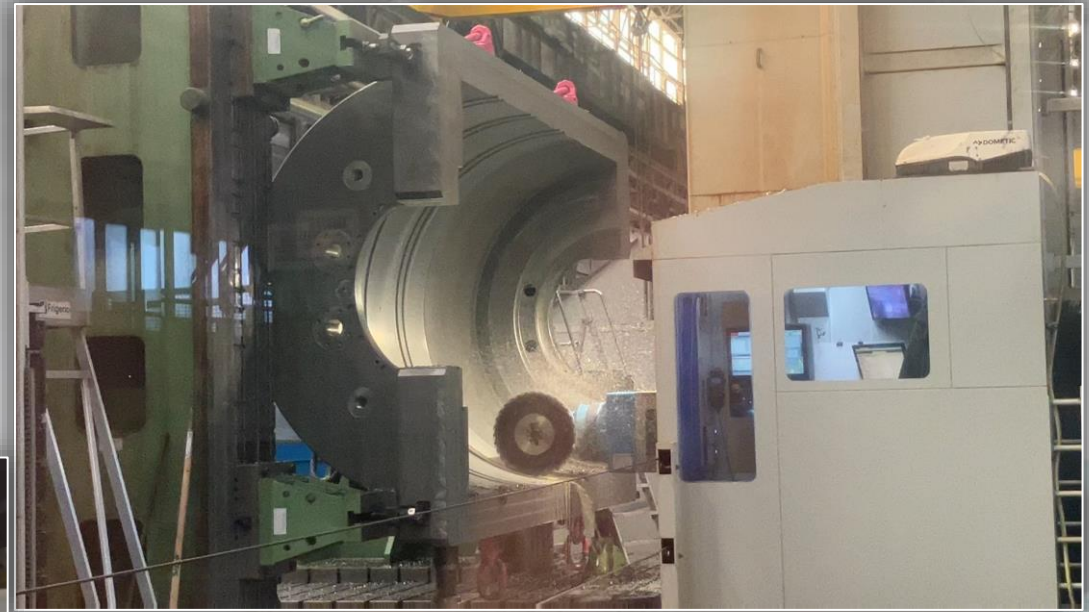

Massive Components

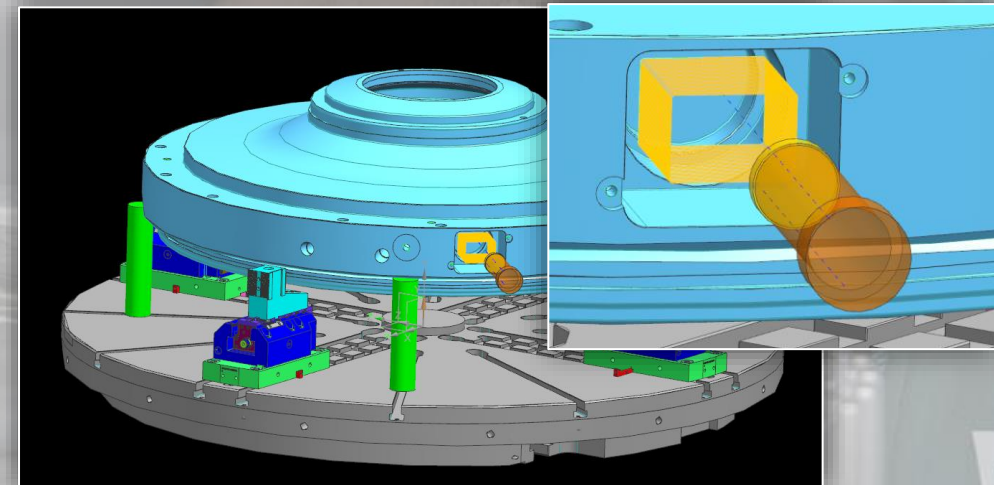

Conventional Cut is core in Stator Components machining

CAD/CAM Strategies and **Simulation** are at the base of **Process Quality**

Measurement System adaptability allows **Manufacturability** and **HSE**

Heavy **Customization** drives **Experience** toward **Continuos Improvement**

Cutting technology are **Continuously** stressed and daily **developed**

Dimensions and **Weights** become critical!

Digital Manufacturing

Energy Valley

Our Products

Centrifugal Compressor



Steam Turbine



Assembly & Testing Custom Cell

Florence

Rotor Assembly

#4 bays
#3 bunkers*

Hydraulic Testing & Painting

#3+2 HT cabins
#2+3 Painting cabins

General Assembly

#5 bays

Standard Testing

#18+4 Test benches

Massa

Hydraulic Testing & Painting

#2 HT cabins
#3 Painting cabins

General Assembly

#6 assembly stations

Standard Testing

#4 test benches

Our Mission

"Our mission is to satisfy customer needs & business expectations through a decarbonization & energy transition journey, leveraging synergy with wider organization and people cultural transformation"



BCL - Centrifugal Compressor Value Chain

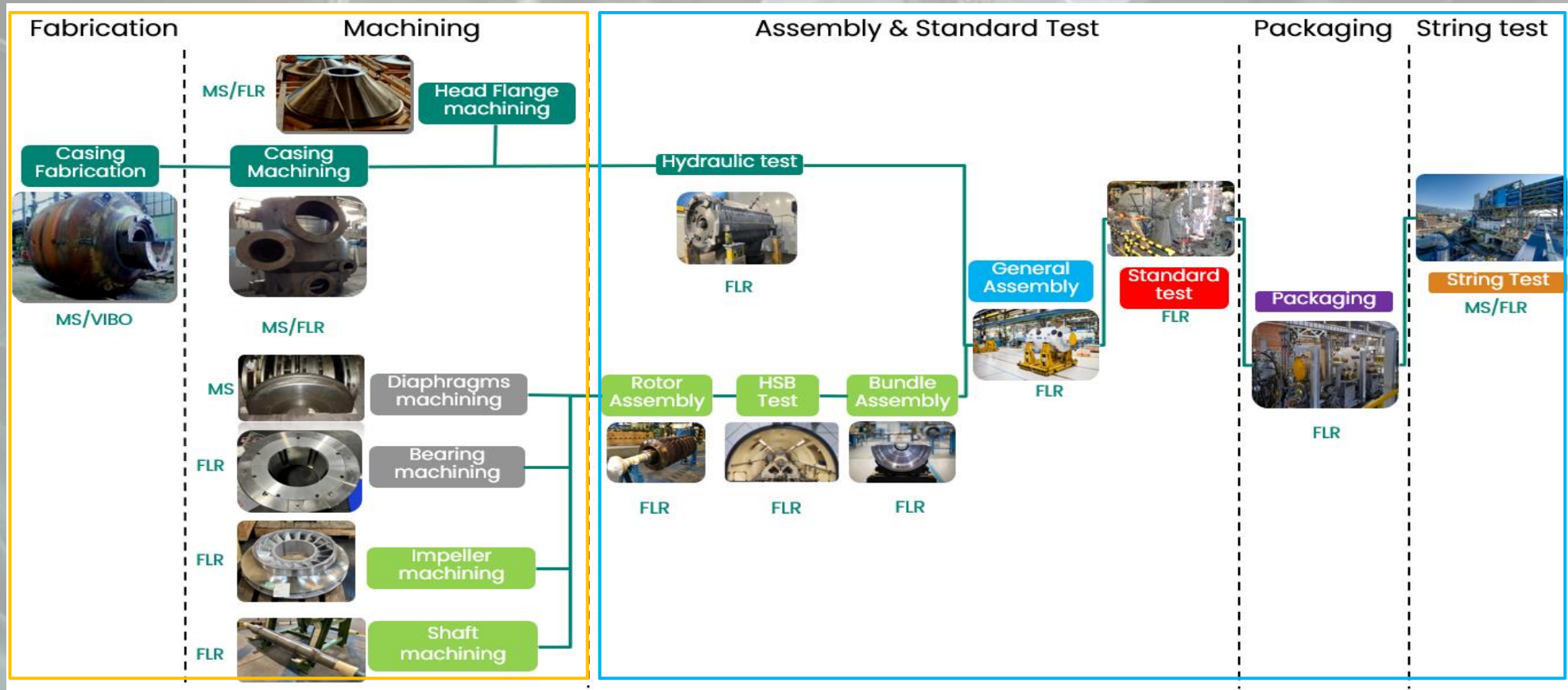

CoE Machining & Fabrication

CoE Assembly, Packaging & Test

Focus on Standard Test and High Speed Balance Test

A standard test and HSB test are mandatory test (API 617):

- **Mechanical running Test**: consists in a mechanical and rotodynamic test of the F2F;
- **Gas Leakage Test**: consists in a pressure test (with nitrogen) for final completeness;
- **Performance Test**: efficiency and prevalence test ;
- **High Speed Balance Test**: rotodynamic test on single rotor;

Our Test Bench



Energy Valley

Assembly & Testing Custom Cell

Standard Centrifugal compressor

Hydrogen Centrifugal Compressor HPRC

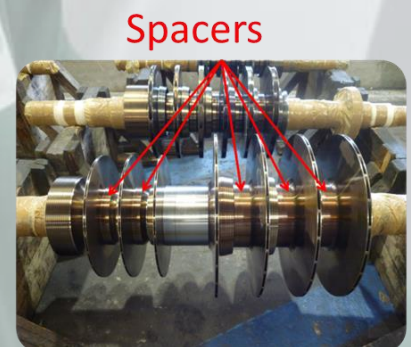
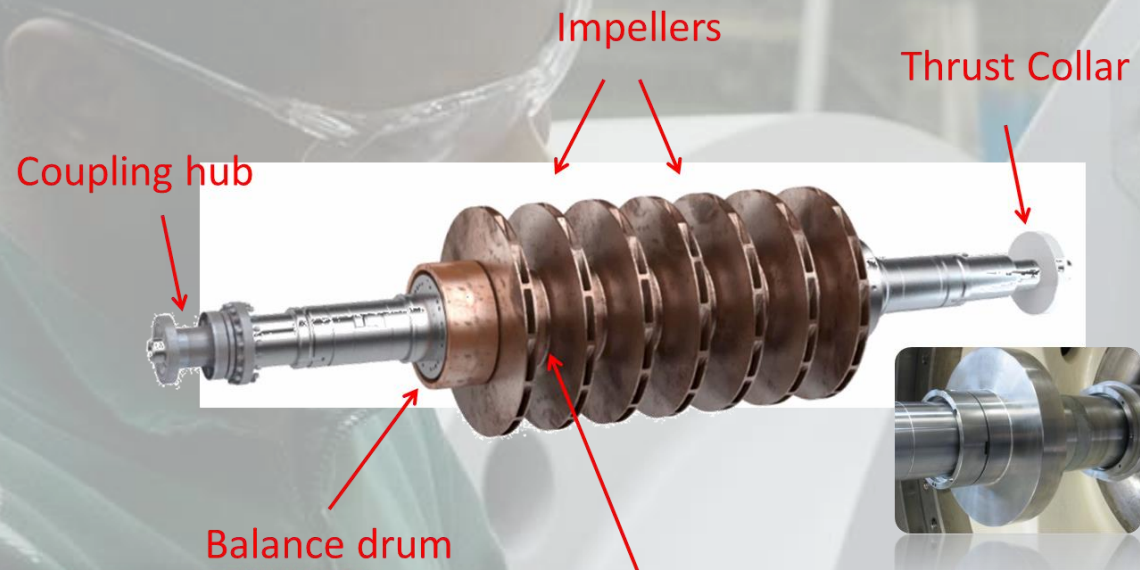

- New Material Technologies
- New Assembly Method
- New Balancing Method
- New Peripheral Speed

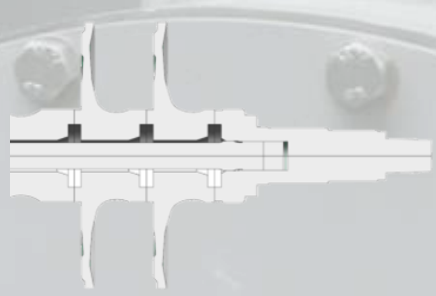

Gas Turbines

Recip Compress.

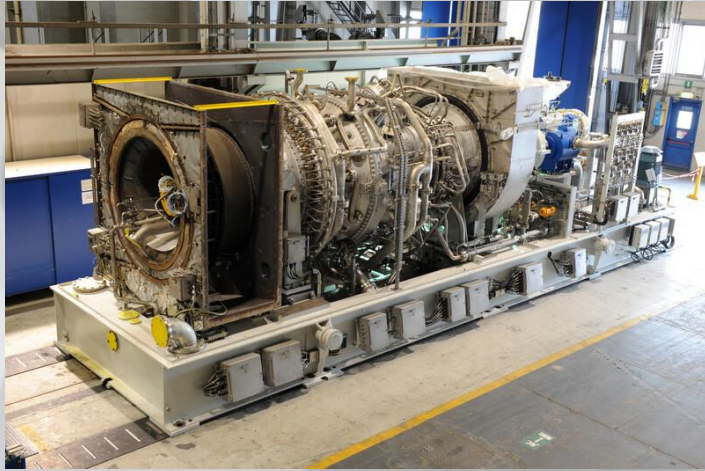
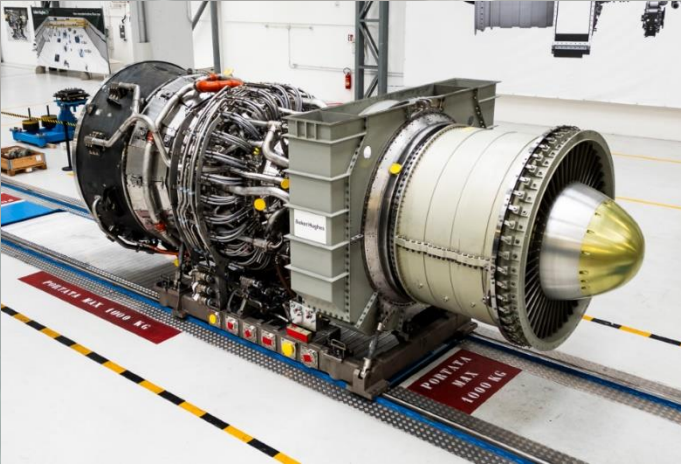

Aeroderivatives

Heavy Duty

API 618 & LDPE

5 – 72 Mw	15000 + Pcs	Up to 44% Ef	2500 h MDO
Offshore	Industrial	Power Gen	Data Center

0,5 - > 72 Mw	300 – 1200 RPM
300 -> 3500 Bar	1 -> 12 Cil

Energy Valley

Assembly & Testing

Flow Cell

Rotor Assy

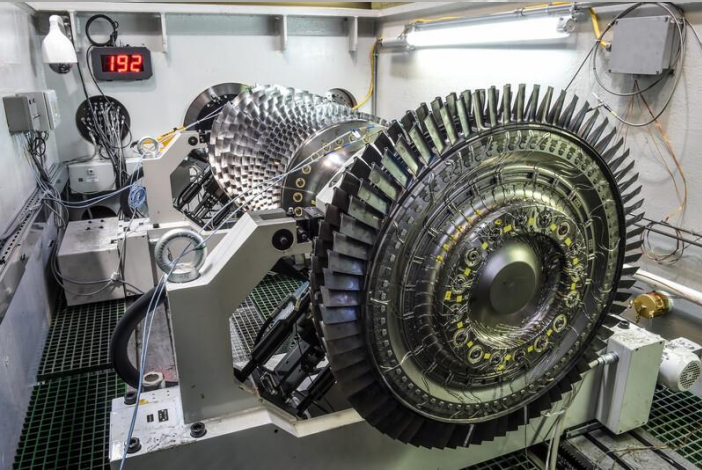

Gen. Assy F2F

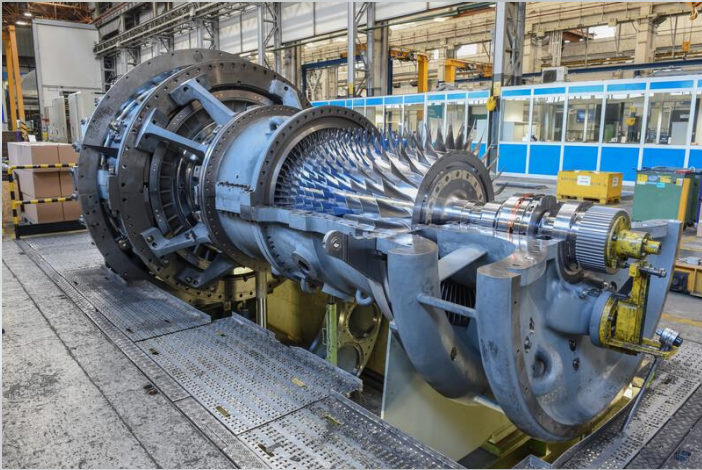

Testing



Non Negotiable HSE & Quality

Blade Assembly	Rotor Run Out Check
----------------	---------------------

Wheels Balance & Grinding	High Speed Balance Test
---------------------------	-------------------------

Spec. Tooling Design	Tolerances & Clearance
----------------------	------------------------

1000+ Checks	Complex Handling
--------------	------------------

Mech. Running Test	Full Load Test
--------------------	----------------

100% Hydrogen Test	Customer Witness
--------------------	------------------

Energy Valley

Honours Programme

Packaging Cell

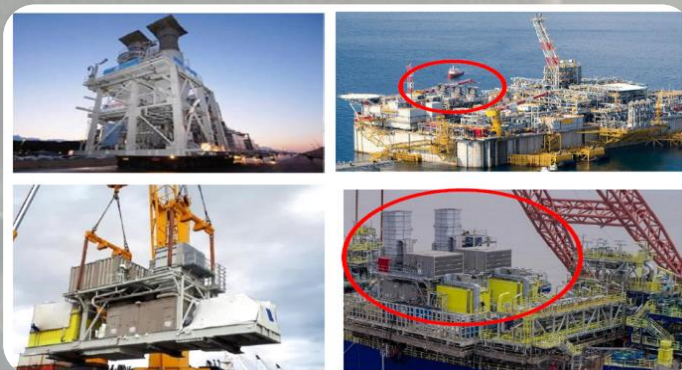

- ✓ Gas Turbines Aero Mounted on Floating Production Storage and Offloading (**FPSO**)
- ✓ Pre-Assembled Unit (**PAU**) solution
- ✓ **Moto-compressors and Steam Turbine skids**
- ✓ Up to **30x6 m** baseplate and **450 tons**
- ✓ **Turbogenerator** Production of electricity up to **50MW** with dedicated electric generator
- ✓ **TurboCompressor** 1 or 2 centrifugal compressors as Gas Booster or Reinjection up to **600bar**

Packaging Path

- Baseplate positioning
- Main item alignment
- Flushing&Funct. test
- Piping&Elect. Assembly

- Painting
- Welding
- NDT (PMI, Idrdraulic test, RX, Dye penetrant test)
- Routing emission (notes, hours, fixtures)

New Hydrogen configuration

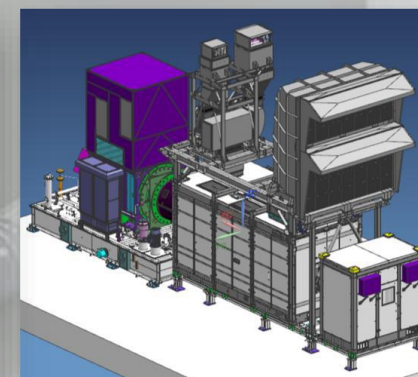

NovoLT 16 H2 Gas Turbine able to start-up, operate & switch-over for any blend of fuel from 100% NG to 100% H2

Packaging activities sequence

–
Turbocompressor

Sequenza delle attività di Packaging

–
Turbocompressore

Honour Programme Supplier Quality

November 27, 2024

Copyright 2024 Baker Hughes Company. All rights reserved. The information contained in this document is company confidential and proprietary property of Baker Hughes and its affiliates. It is to be used only for the benefit of Baker Hughes and may not be distributed, transmitted, reproduced, altered, or used for any purpose without the express written consent of Baker Hughes.



Supplier Quality Organization

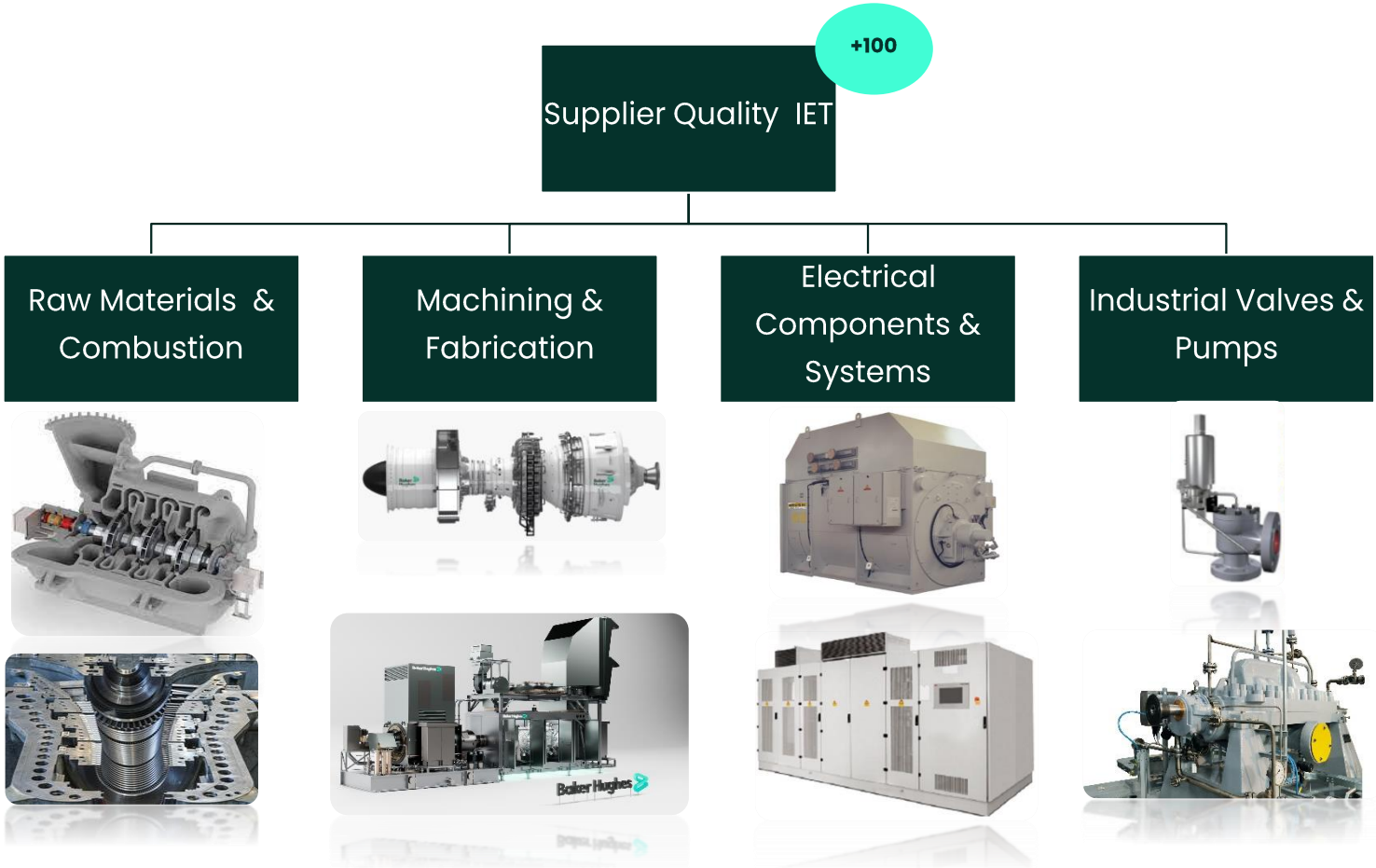
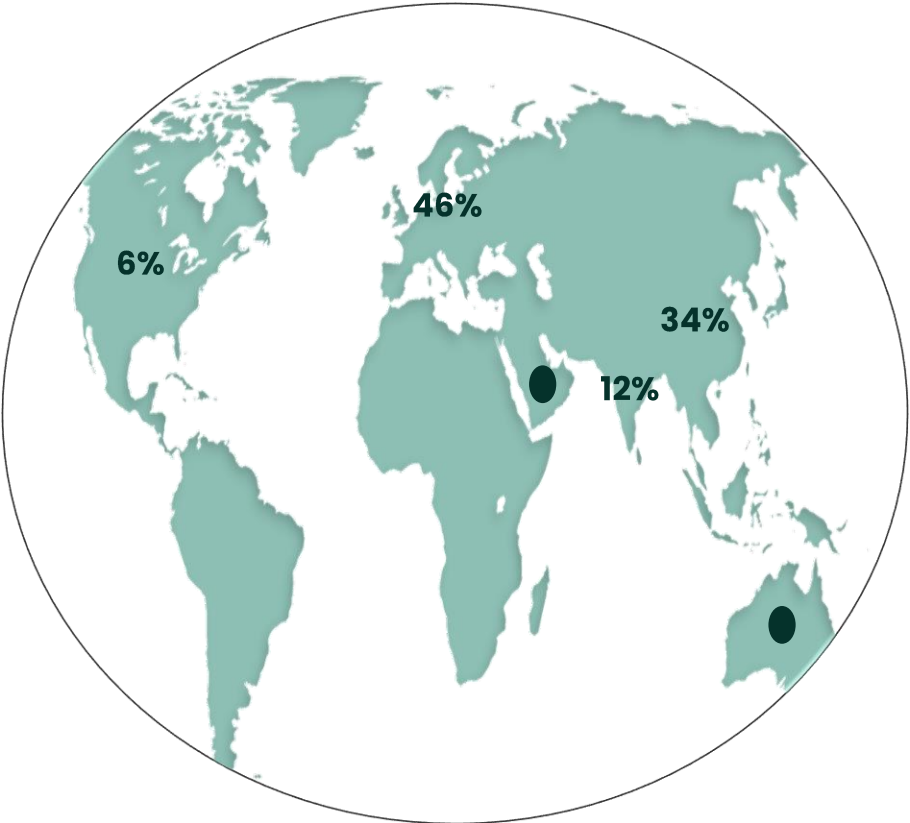

ISO 9001:2015 Quality Management Systems



Purchasing	Monitoring and Measurement	Improvement
<p>§8.4</p> <p>Provided product conformity</p> <p>Selection of suppliers capable of supplying conform product</p> <p>Approval of product, procedures, process and equipment</p> <p>Personnel qualification and QMS requirements</p>	<p>To demonstrate product and QMS conformity</p> <p>§9.2</p> <ul style="list-style-type: none"> • <i>By measuring characteristics of product to verify requirements addressing (audit)</i> <p>To guarantee QMS effectiveness</p> <p>§9.3</p> <ul style="list-style-type: none"> • <i>By verifying process ability in reaching planned results (metrics)</i> 	<p>To continually improve QMS effectiveness</p> <p>§10.1, §10.2, §10.3</p> <ul style="list-style-type: none"> • <i>By quality policy application, quality objectives definition and review, audit results, analysis of data, CAPA management review</i>

Supplier Quality key processes

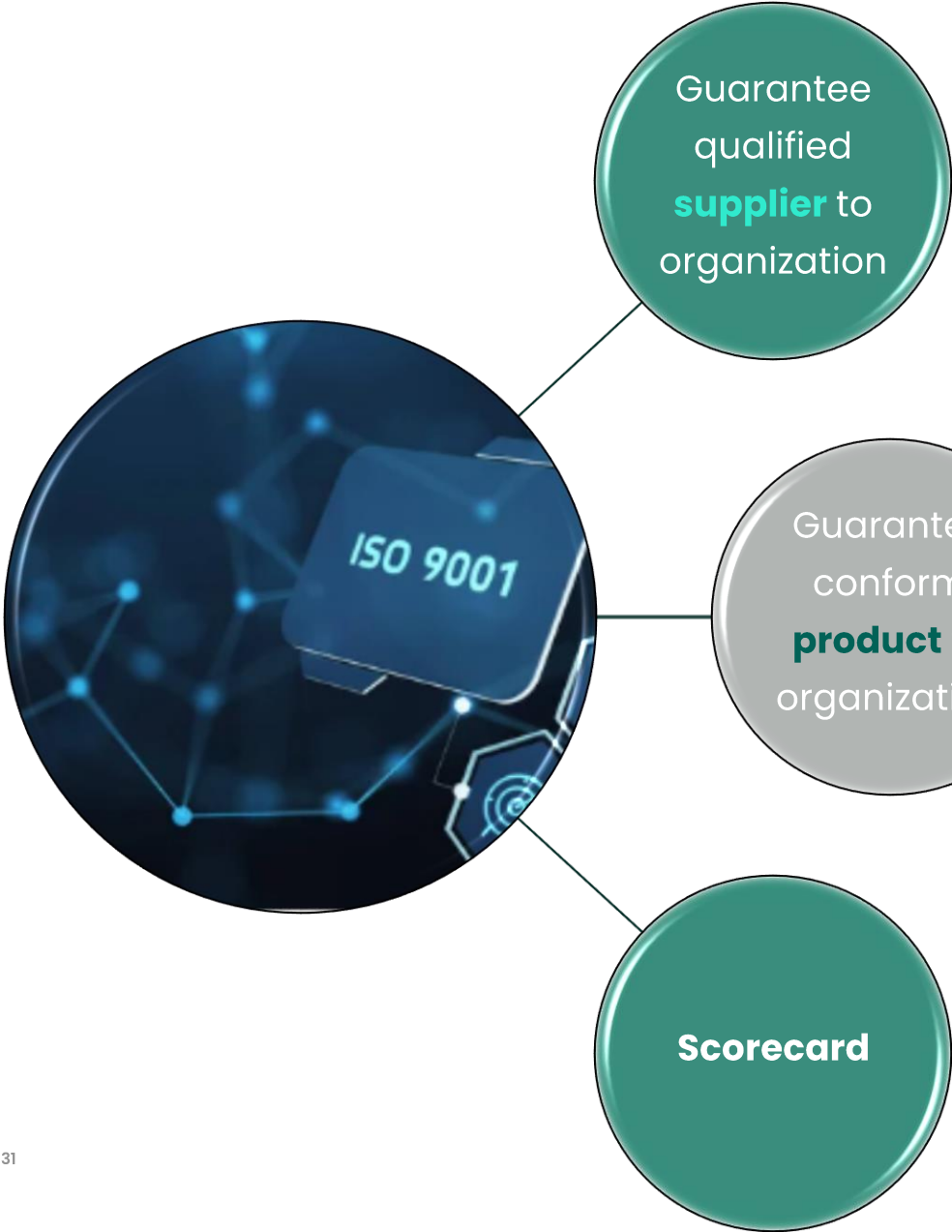

- Scouting & Approval
- Qualification (product related special processes: Welding, Non-Destructive Testing, Painting)
- Surveillance

- Supplier inspection
- Deviations Management

- Supplier performance monitoring

Honour Programme



A qualification example: LT16 Combustion main buy items

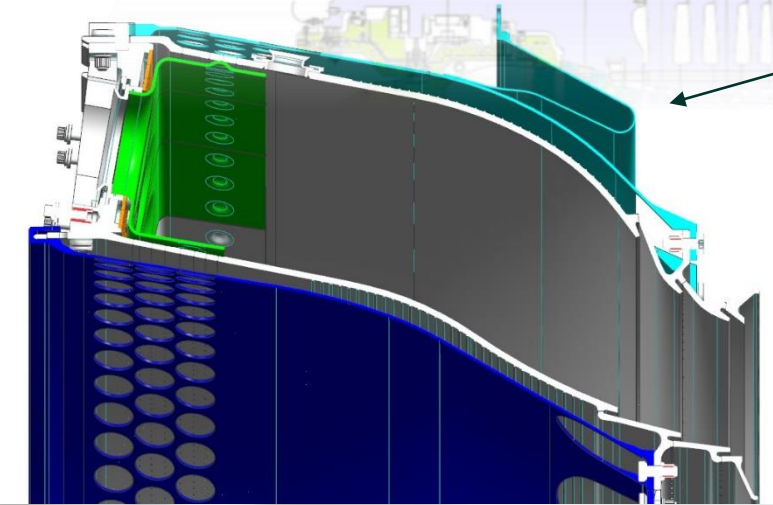
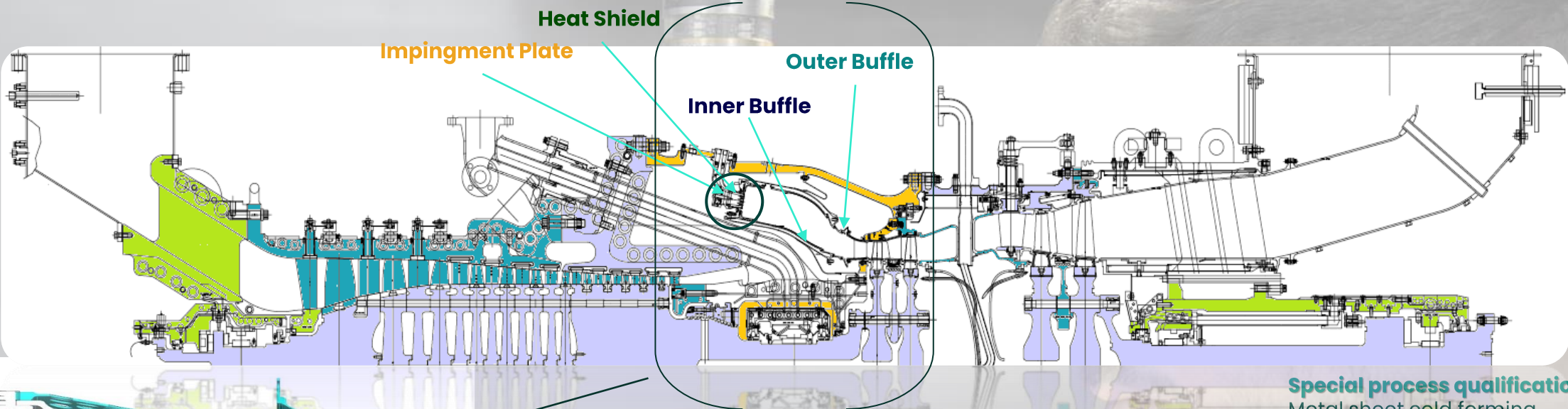

Impingement Plate



Heat Shield



Inner Baffle



Outer Baffle

Special process qualification

Metal sheet cold forming
Super-alloy not conventional machining:

- Laser cutting
- Electrical Discharge Machining
- Water-jet cutting
- Metal Spinning

Welding (Tungsten Inert Gas)
Electron beam welding
Coating (High Velocity Oxygen Fuel)

Non-Destructive Tests:

- Visual Test
- Penetrant Test
- Ultrasonic Test
- Radiographic Test

Dimensional check:

- Coordinate Measuring Machines
- Blue light Scan

Supplier performance monitoring: non-conformity & corrective action

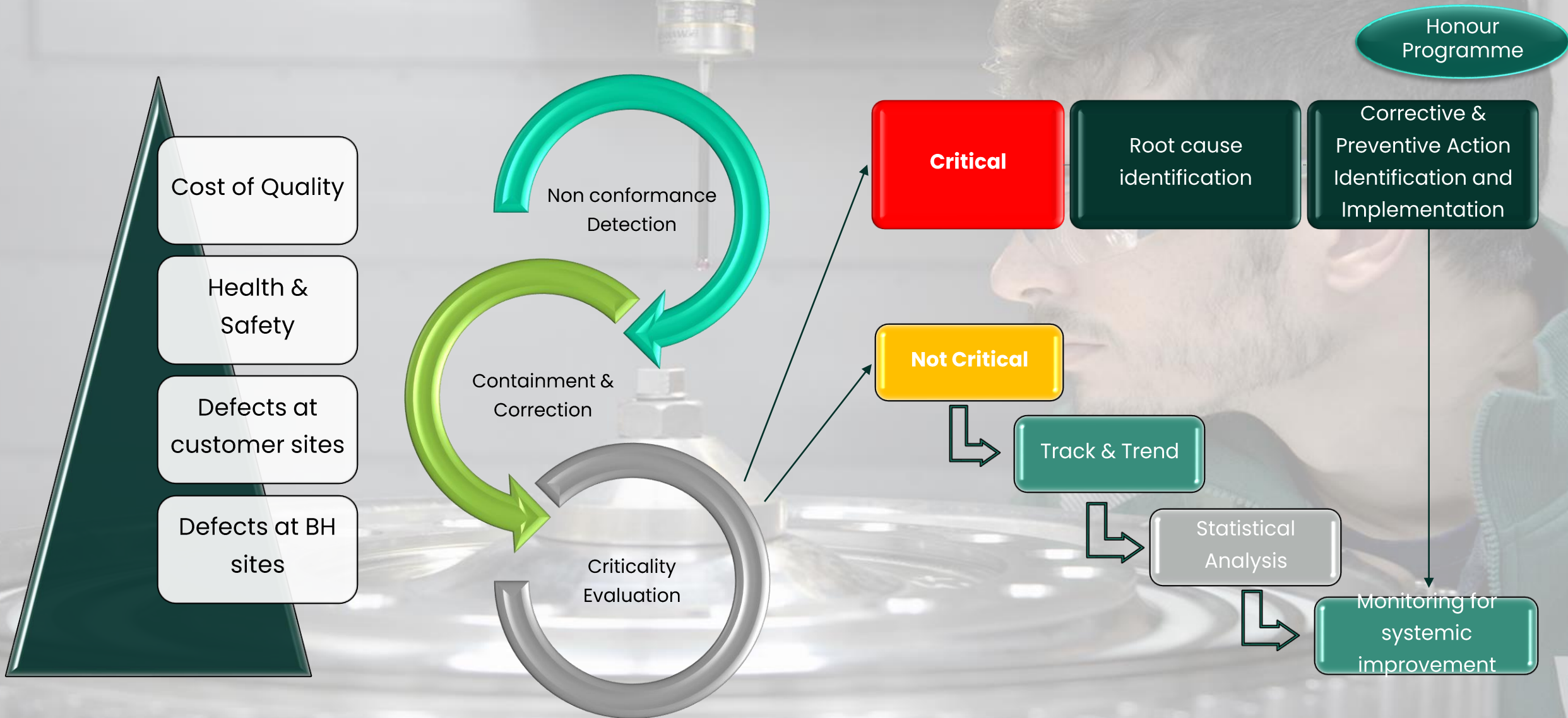

Quality issue – Case study

- **Problem statement:** casting defects inside discharge valves of RC Cylinder detected at BH Florence plant
- **Root cause:** Process-Deformation of mold upper part, compromising feeding power; Method-Ultrasonic Test failure
- **Solution:** Pouring method and UT check improved, effectiveness's validated by BH

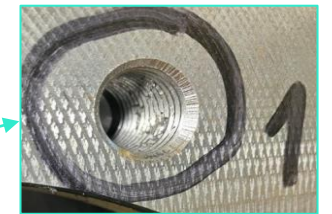
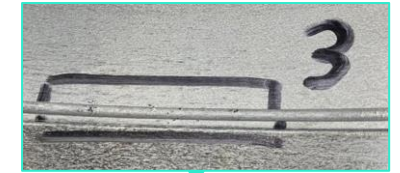
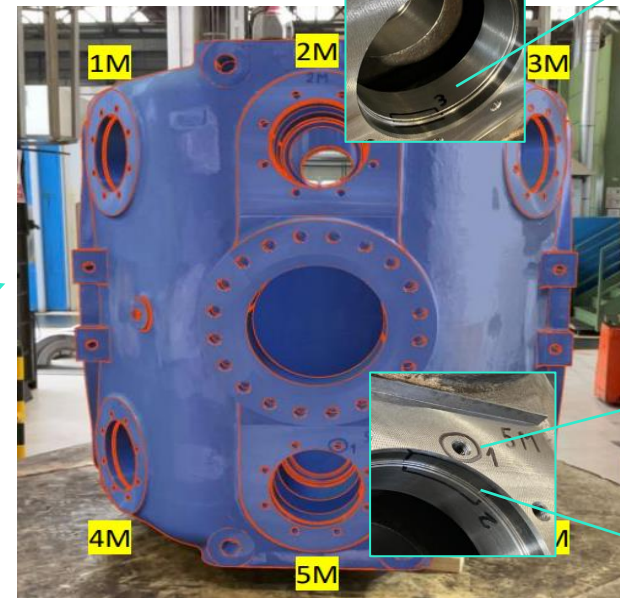
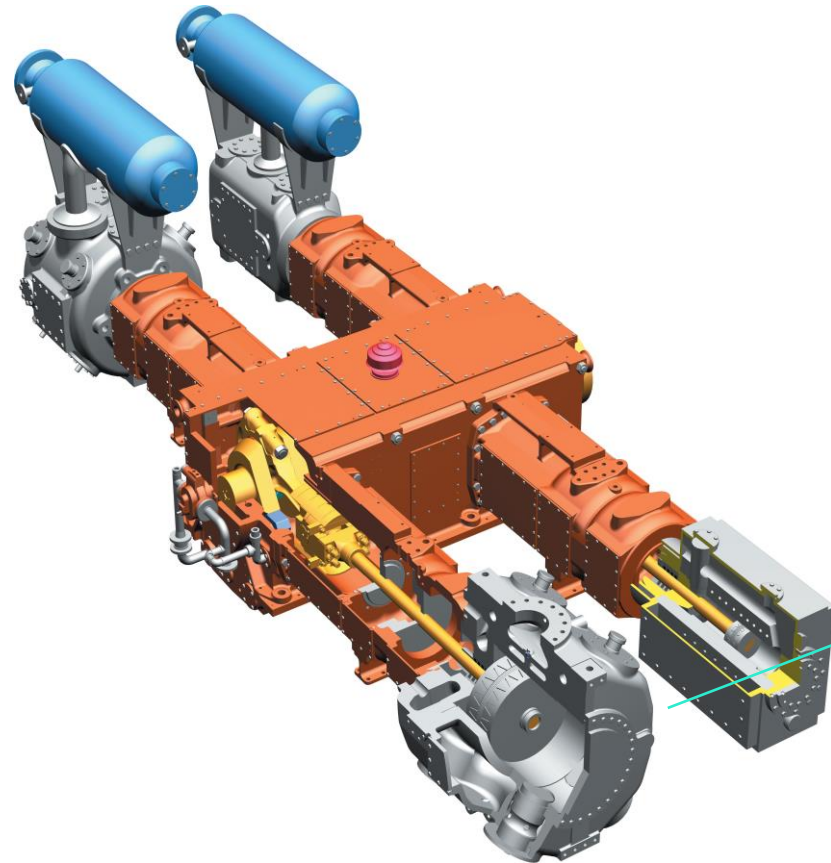

Tools to determine Cause & Effect Analysis

Fishbone methodology

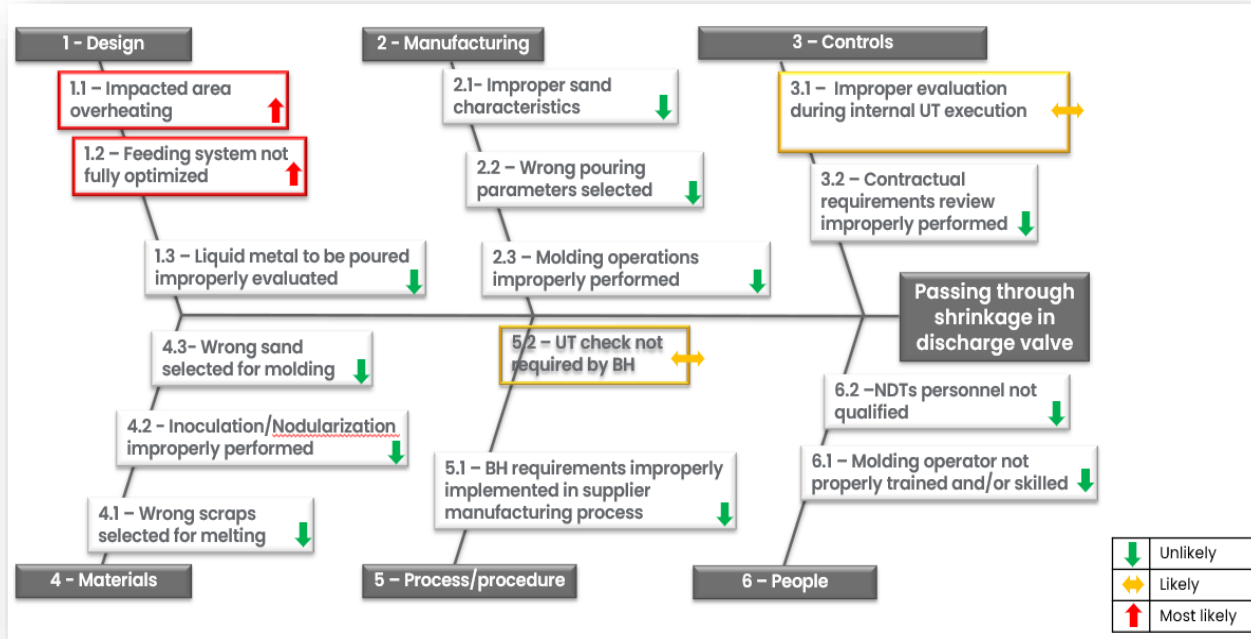

5-Why Methodology

1 Why did the Problem occur? ↑



2 Why did the Problem was not detected? ↔

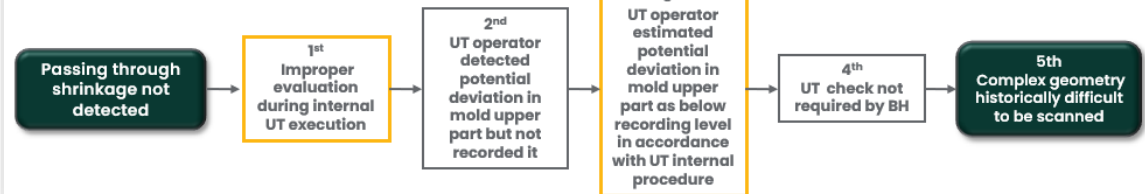

One Team, One Goal driven by Diversity, Equity, Inclusion and focused on excellence



Creating a greener tomorrow, today



Quality first: Ensuring Continuous Improvement in every step of Supply Chain

Baker Hughes

IET Business System for Energy Valley Project

November 27, 2024

Copyright 2024 Baker Hughes Company. All rights reserved. The information contained in this document is company confidential and proprietary property of Baker Hughes and its affiliates. It is to be used only for the benefit of Baker Hughes and may not be distributed, transmitted, reproduced, altered, or used for any purpose without the express written consent of Baker Hughes.

IET Business System (Kaizen change model) Explained:

We adopted **Kaizen Business System**:

- **Strategy Deployment & Execution** -> **how the business identifies its True North, Breakthrough priorities and required capabilities**
- **Value Stream Transformation** -> **how the business identifies and delivers breakthrough improvements**
- **Daily Management** -> **how each team removes waste, solves problems and improves work every**

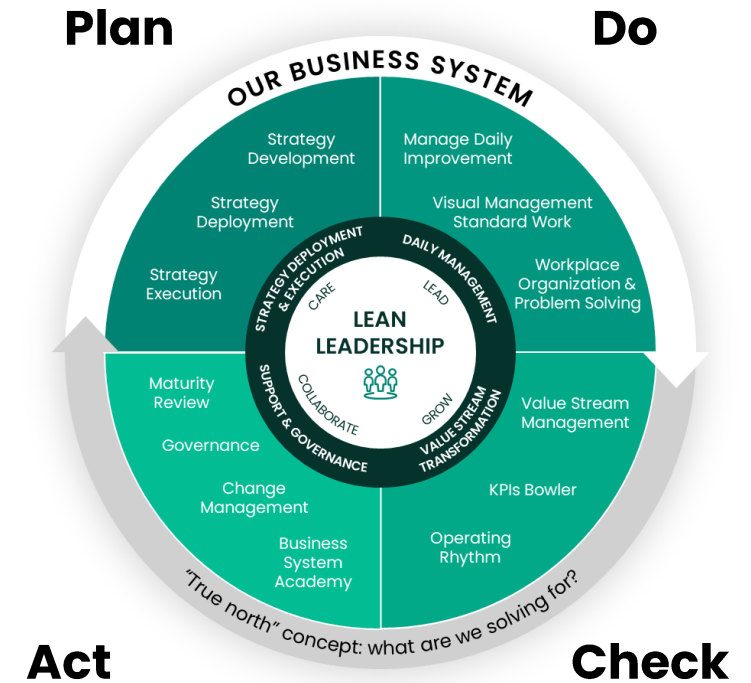

Lean Leadership creates the conditions where all staff engage & contribute to continuous improvement, standardization, problem visibility and cross functional collaboration

IET Business System – Model vs Strategy

The Strategy

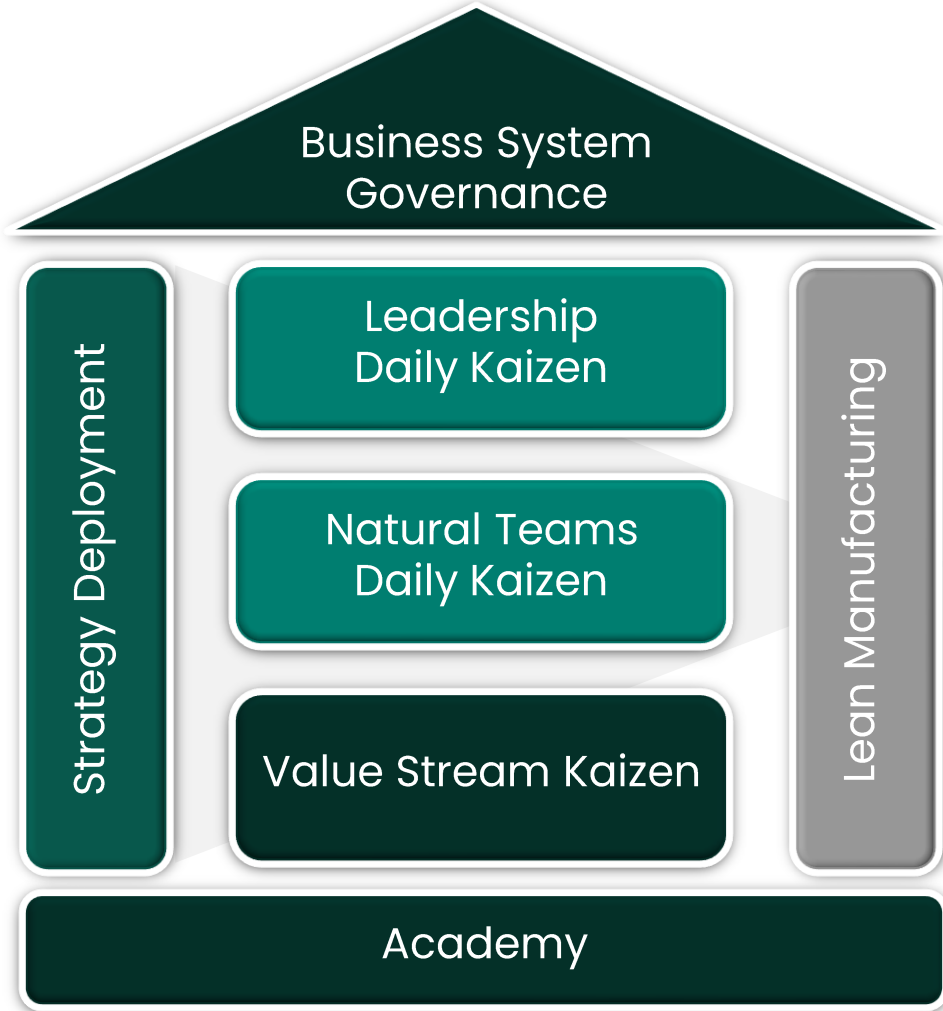

The Model

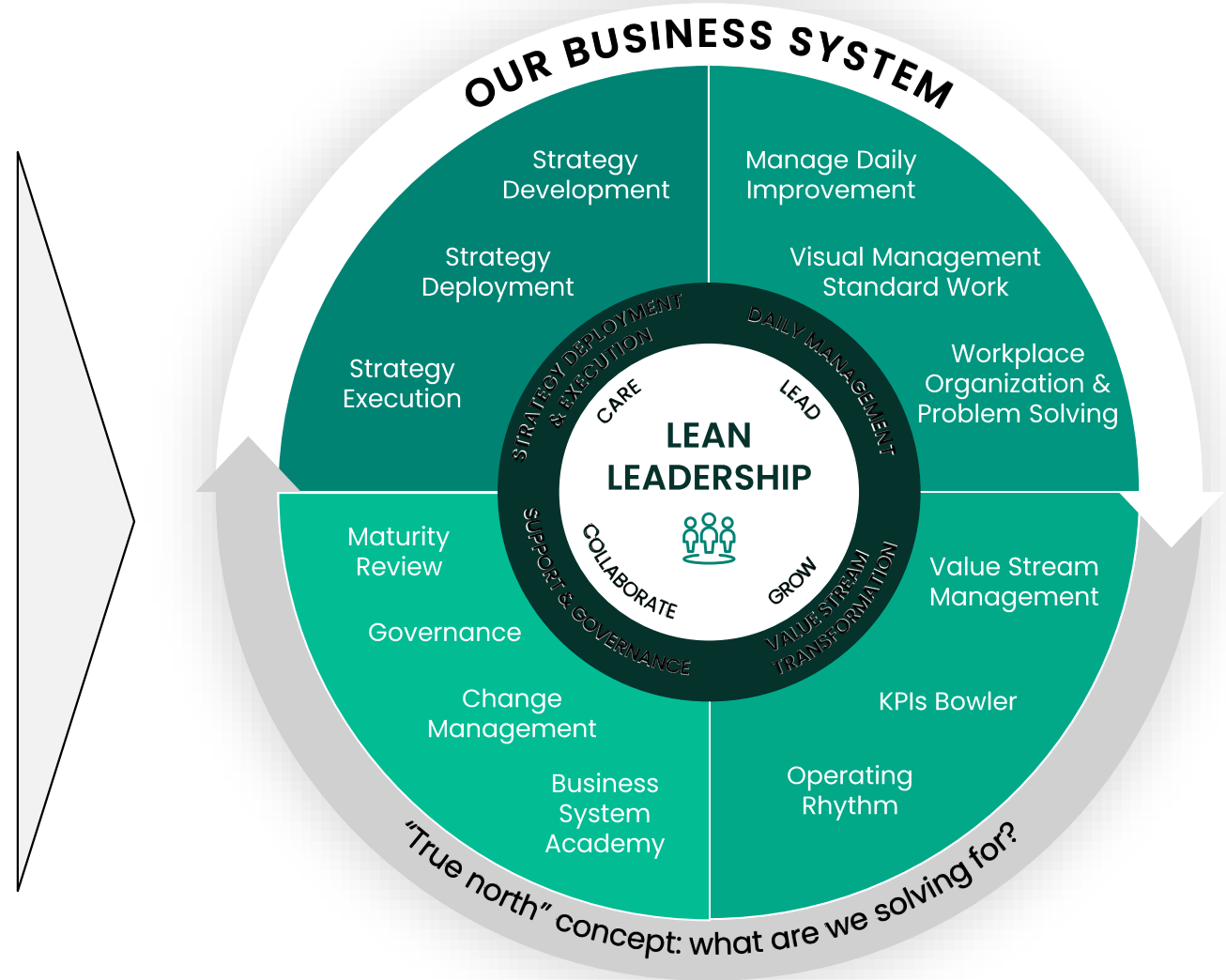

IET Business System Value Proposition

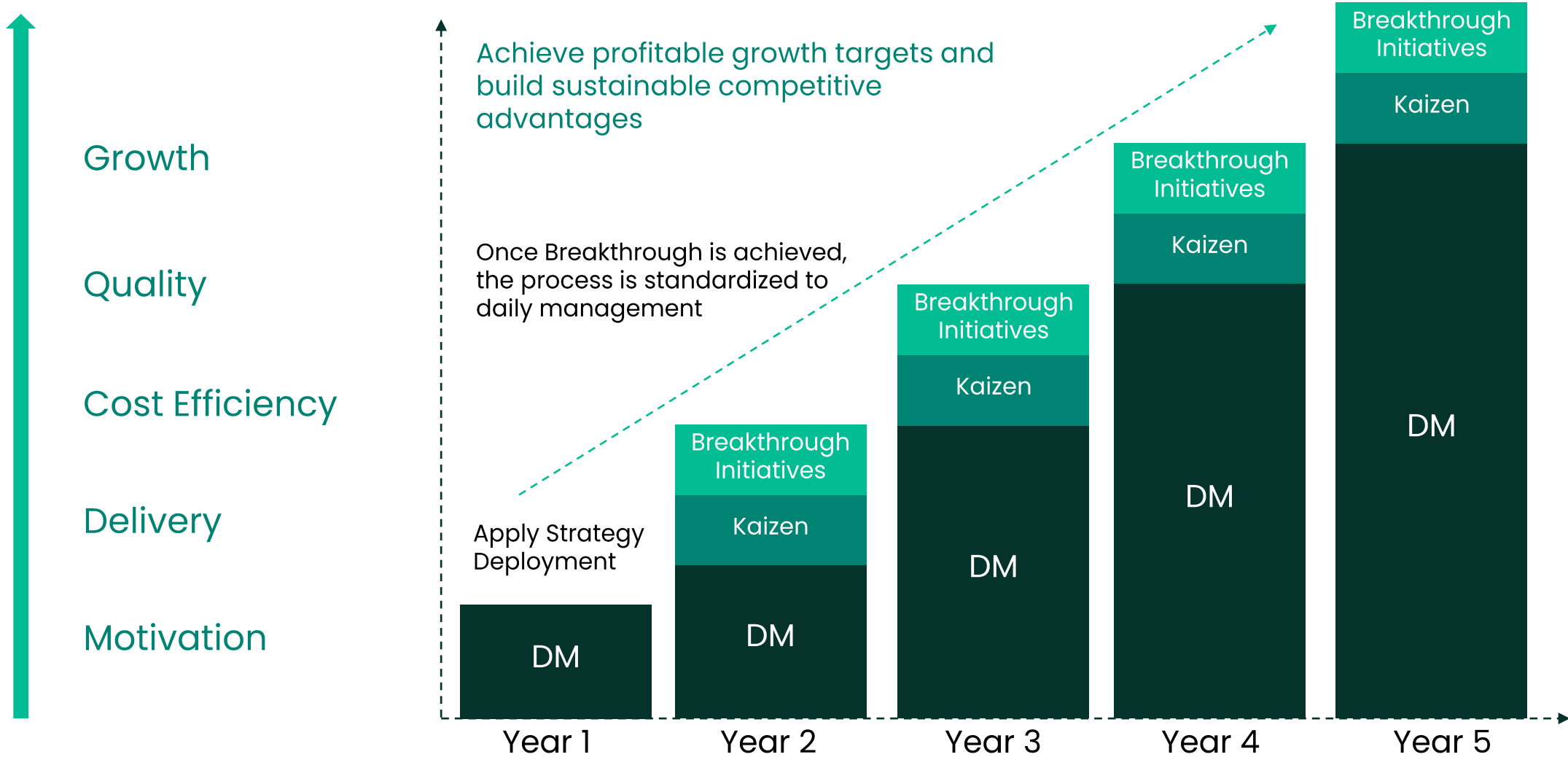

Key numbers

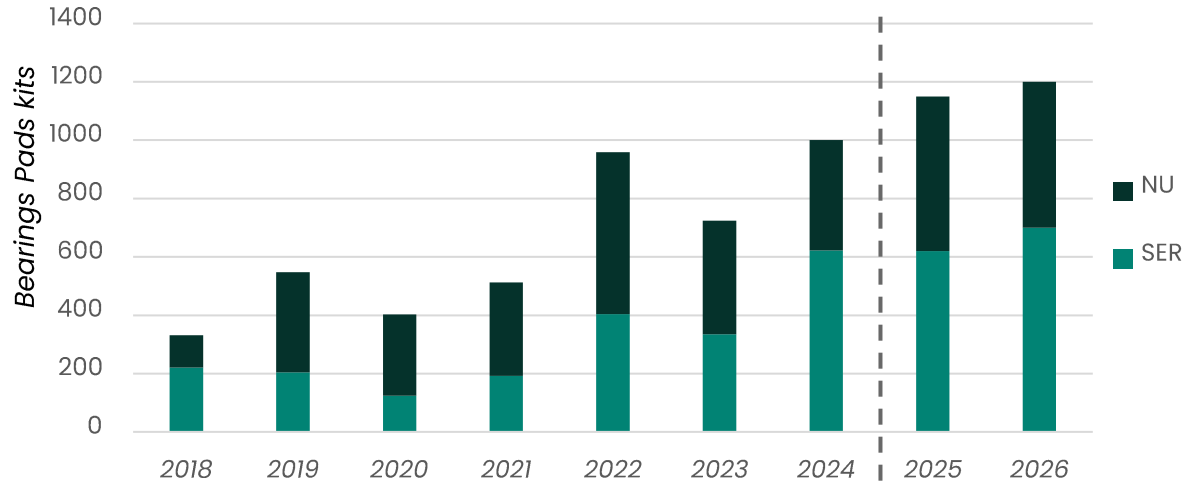

- **Reinsourced scope for Thrust bearings...** resulting as multiplier on Service growth
- **20% productivity Vs BUY for Bearings**
- **Operation Equipment Efficiency improved** from 13% to 47%

Improvement Roadmap

- ✓ **Planning KPIs & Throughput Dashboard '21**
- ✓ **Standardization** of neutral pads for 50% of the production (**decoupling point**)
- ✓ **Line Lean Re-Layout '23 and simplification of SC strategy**
- ✓ **Rationalization of tooling setup '24**
- ✓ **Visual management on Bottlenecks**



Baker Hughes Workshop Tour

Honours Programme Call for Application

November 27, 2024

Copyright 2024 Baker Hughes Company. All rights reserved. The information contained in this document is company confidential and proprietary property of Baker Hughes and its affiliates. It is to be used only for the benefit of Baker Hughes and may not be distributed, transmitted, reproduced, altered, or used for any purpose without the express written consent of Baker Hughes.

Do you want to know more about Baker Hughes Technology?

Attend the Tour:

Honours
Programme

Nuovo Pignone Campus MFG Tour
Thursday 5 th of December
15:00 to 17:00

FIR Entrance
Via Dei Perfetti Ricasoli 11

NOTE:

Leave your name at the end of the Seminar

CDMP Contacts:

Giovanni.DelPanta@bakerhughes.com

Francesco.Cardini@bakerhughes.com

Luca.Palatiello@bakerhughes.com

UNIFI Contacts:

Mario.Tucci@unifi.it

Carlo.Carcasci@unifi.it

Rocco.Furferi@unifi.it

Filippo.Decarlo@unifi.it

Call For Application: Honours Programme

Baker Hughes – UNIFI Honours Programme \Energy Valley Project

Manufacturing Engineer Turbomachinery: Manufacturing Technology – Rotor – CC Impeller

COMPETENCY AREA	COMPETENCY/TASK DESCRIPTION	TYPE	COURSE NAME	COURSE CODE	DURATION	DESCRIPTION
Manufacturing Production	Knowledge of routing emission	OJT	OJT with ME	Activity on the job	8	OJT with a ME in Subdivision Des
	Basic knowledge of EDM	OJT	OJT on EDM	Activity on the job	8	Des from the Pa the risks of operatio

Machining



Baker Hughes – UNIFI Honours Programme \Energy Valley Project

Manufacturing Engineer Turbomachinery: CC-ST Assembly Custom

COMPETENCY AREA	COMPETENCY/TASK DESCRIPTION	TYPE	COURSE NAME	COURSE CODE	DURATION	DESCRIPTION
Manufacturing Production	Testing Plans, Exception Management & NCR	OJT	OJT with ME Cell Inspectors- PQE cell	Activity on the job	4	OJT with a Senior ME on Check Plans (CTO – CTP) certificates – Non conformities- instructions and exceptions
	Knowledge of Balancing & Overspeed OJT	OJT	OJT on Balancing & Overspeed	Activity on the job	8	OJT on Balancing & Overspeed
	Knowledge on MI & Performance Test CDST	OJT	OJT on MI & Performance Test CDST	Activity on the job	8	OJT on MI & Performance Test CDST

Assembly Testing Packaging



Baker Hughes – UNIFI Honours Programme \Energy Valley Project

Supplier Quality Engineer: Auditor

COMPETENCY AREA	COMPETENCY/TASK DESCRIPTION	TYPE	COURSE NAME	COURSE CODE	DURATION	DESCRIPTION
Supplier Quality Engineer	Knowledge of Welding process	OJT	Workshop experience (Welding)	Activity on the job	8	Workshop experience (Welding)
	Knowledge of Heat Treatment process	OJT	Workshop experience (Heat Treatment)	Activity on the job	8	Workshop experience (Heat Treatment)
	Knowledge of Plating process	OJT	Workshop experience (Plating)	Activity on the job	8	Workshop experience (Plating)

Supplier Quality Engineer



8 Competency Paths:

- Manufacturing Engineer Turbomachinery: Manufacturing Technology – Rotor – CC Impeller
- Manufacturing Engineer Turbomachinery: Manufacturing Technology – Stator – Head Flange
- Manufacturing Engineer Turbomachinery: Manufacturing Technology Rotor GT Wheel

- Manufacturing Engineer Turbomachinery: CC-ST Assembly Custom
- Manufacturing Engineer Turbomachinery : GT Assembly Flow
- Manufacturing Engineer Turbomachinery: MC Packaging

- Supplier Quality Engineer: Non Conformity Analysis
- Supplier Quality Engineer: Auditor

Download the Paths and come to the Tour with your Questions

Baker Hughes 